

Honeywell CORE Drive

SPECIFICATION DATA



APPLICATION

The new Honeywell VFD CORE drive addresses the need to save time for installation and provides the low total installed cost with years of energy savings. The VFD CORE Start-up Wizard is designed to ease and expedite the VFD Commissioning Process. The Wizard consists of critical commissioning questions to intuitively guide users through parameter setup process, which covers nearly all your commercial heating, ventilation and air conditioning (HVAC) applications.

Additionally, the VFD CORE is rated for constant torque for the industrial applications. The VFD CORE is the great full-featured base drive that will meet the majority of building needs and offer the commissioning in minutes.

FEATURES

- **Easy Installation & Monitoring**
 - Startup Wizards for fast commissioning
 - Quick Start Guide
 - Built-In real time clock
- **Easy Communication**
 - Intuitive graphical keypad in 5 languages—English, Spanish, Portuguese, French and Mandarin
 - Integrated Modbus®: RS485
 - Memory in keypad—up to 4 complete parameter sets
 - Local / Remote button on keypad
 - Automatic Fault Reset
 - Available optional protocols
- **Protection**
 - Drive is NEMA1 rated and keypad is NEMA4 rated
 - Plenum rated
 - Conformal Coated Board
 - 3% DC choke above 60 HP for 460V and above 50 HP for 230V
- **High-performance Technology**
 - Control bandwidth up to 600Hz
 - 6-pulse IGBT, PWM technology
 - Speed/Torque/Position control mode
 - Dual rating design HVAC (normal duty), and industrial (heavy duty)
 - PID with Sleep Mode
- **Versatile Driving Controls**
 - Built-in safe stop function
 - Built-in brake unit
 - Support for various network protocols
- **Modular Design**
 - Detachable digital keypad
 - I/O extension cards
 - Replaceable fan
 - Compact sizes
- **Environmental Adaptability**
 - 14-104° F operation temperature
 - Global safety standards (CE/UL/cUL)
- **Warranty**
 - 3 years
 - Repair available



SPECIFICATION TABLES

Table 1. GENERAL SPECIFICATIONS

Control Characteristics	Control Method	1: V/F (V/F control); 2: SVC (Sensorless Vector Control)				
	Starting Torque	Reach up to 150% or above at 0.5Hz.				
	V/F Curve	4 point adjustable V/F curve and square curve				
	Speed Response Ability	5Hz				
	Torque Limit	Heavy Duty: Max.170% torque current				
	Torque Accuracy	±5%				
	Max. Output Frequency (Hz)	230V series: 600.00Hz (55kw and above: 400.00Hz); 460V series: 600.00Hz (90KW and above: 400.00Hz)				
	Frequency Output Accuracy	Digital command:±0.01%, -10C~+40C, Analog command: ±0.1%, 25±10C				
	Output Frequency Resolution	Digital command: 0.01Hz, Analog command: max. output frequency x 0.03/60 Hz (±11 bit)				
	Overload Tolerance	Normal duty: 120% of rated current for 1 minute Heavy duty: 120% of rated current for 1 minute;160% of rated current for 3 seconds				
	Frequency Setting Signal	0~+10V, 4~20mA, 0~20mA, pulse input				
	Accel./Decel. Time	0.00~600.00/0.0~6000.0 seconds				
	Main control function	Fault restart	Parameter copy	Dwell	BACnet COMM	Momentary power loss ride thru
		Speed search	Over-torque detection	Torque limit	16 preset speed options	Accel/Decel. time switch
		S-curve accel/ decel	3-wire sequence	Auto-Tuning (rotational, stationary)	Frequency upper/ lower limit settings	Cooling fan on/off switch
Slip compensation		Torque compensation	JOG frequency	MODBus communication (RS-485 RJ45, max. 115.2 kbps)	DC injection braking at start/ stop	
Smart Stall		PID control (with sleep function)	Energy saving control			
Fan Control	230V series					
	Model HCRDA0200B1000T (20HP) and above are PWM controlled					
	Model HCRDA0150B1000T (15HP) and below are on/off switch controlled					
	460V series					
	Model HCRDC0200B1000T and above are PWM controlled Model HCRDC0150B1000T (15HP) and below are on/off switch controlled					

Protection Characteristics	Motor Protection	Electronic thermal relay protection
	Over-current Protection	Normal Duty: Over-current protection for 240% rated current
		Current clamp Normal duty: 170~175%
	Over-voltage Protection	230: drive will stop when DC-BUS voltage exceeds 410V
		460: drive will stop when DC-BUS voltage exceeds 820V
	Over-temperature Protection	Built-in temperature sensor
	Stall Prevention	Stall prevention during acceleration, deceleration and running independently
	Restart After Instantaneous Power Failure	Parameter setting up to 20 seconds
Grounding Leakage Current Protection	Leakage current is higher than 50% of rated current of the AC motor drive	
International Certifications	CE, GB 12668.3 	

Table 2. VFD CORE Technical Specifications.

Environment	Installation location	IEC60364-1/IEC60664-1 Pollution degree 2, Indoor use only		
	Surrounding Temperature	Storage: -25°C / -13°F ~ +70°C / 167°F	Transportation: -25 °C / -13°F ~ +70 °C / 167°F	
		Non-condensation, non-frozen		
	Rated Humidity	Operation: Max. 90%	Storage/Transportation: Max. 95%	
		No condensing water		
	Air Pressure	Operation/ Storage: 86 to 106 kPa	Transportation: 70 to 106 kPa	
	Pollution Level	IEC721-3-3		
Operation: Class 3C2; Class 3S2		Storage: Class 2C2; Class 2S2	Transportation: Class 1C2; Class 1S2	
No concentrate Conformal coated boards				
Altitude	Operation	If VFD is installed at altitude 0~1000m, follow normal operation restriction. If it is installed at altitude 1000~3000m, decrease 2% of rated current or lower 0.5°C of temperature for every 100m increase in altitude. Maximum altitude for Corner Grounded is 2000m.		
	Storage	ISTA procedure 1A(according to weight) IEC60068-2-31		
Package Drop	Transportation	ISTA procedure 1A(according to weight) IEC60068-2-31		
Vibration	1.0mm, peak to peak value range from 2Hz to 13.2 Hz; 0.7G~1.0G range from 13.2Hz to 55Hz; 1.0G range from 55Hz to 512 Hz. Comply with IEC 60068-2-6			
Impact	IEC/EN 60068-2-27			
Operation Position	Max. allowed offset angle ±10° (under normal installation position)			
Plenum Rating	Compliance with UL 508C, the Standard for Power Conversion Equipments, 3rd Edition, and the Canadian Standard for Industrial Control Equipment, C22.2-No. 14.			

Table 3. VFD CORE 208/230 VAC, Input and Output Rating.

Frame size			A					B			C			D		E		
Model HCRDAxxxxx1000T			1hp	2hp	3hp	5hp	7.5hp	10hp	15hp	20hp	25hp	30hp	40hp	50hp	60hp	75hp	100hp	125hp
Output Rating	Normal "HVAC" Duty - Variable Torque	Rated Output Capacity (kVA)	2	3	4	6	8.4	12	18	24	30	36	42	58	72	86	110	128
		Rated Output Current (A)	5	7.5	10	15	21	31	46	61	75	90	105	146	180	215	276	322
		Applicable Motor Output (kW)	0.75	1.5	2.2	3.7	5.5	7.5	11	15	18.5	22	30	37	45	55	75	90
		Applicable Motor Output (HP)	1	2	3	5	7.5	10	15	20	25	30	40	50	60	75	100	125
		Overload tolerance	120% of rated current for 1 minute															
		Max. output frequency (Hz)	600.00Hz (55KW~: 400.00Hz)															
		Carrier Frequency (kHz)	2~15kHz (8KHz)						2~10kHz (6kHz)						2~9kHz (4KHz)			
	Heavy Duty - Constant Torque	Rated Output Capacity (kVA)	1.8	2	3.2	4.4	6.8	10	13	20	26	30	36	48	58	72	86	102
		Rated Output Current (A)	4.6	5	8	11	17	25	33	49	65	75	90	120	146	180	215	255
		Applicable Motor Output (kW)	0.4	0.75	1.5	2.2	3.7	5.5	7.5	11	15	18.5	22	30	37	45	55	75
		Applicable Motor Output (HP)	0.5	1	2	3	5	7.5	10	15	20	25	30	40	50	60	75	100
		Overload tolerance	120% of rated current for 1 minute, 160% of rated current for 3 seconds															
		Max. output frequency (Hz)	600.00Hz(55KW~: 400.00Hz)															
		Carrier Frequency (kHz)	2~15kHz (8KHz)						2~10kHz (6kHz)						2~9kHz(4KHz)			
Input Rating	Input Current (A) Normal Duty	6.4	9.6	15	22	25	35	50	65	83	100	116	146	180	215	276	322	
	Input Current (A) Heavy Duty	3.9	6.4	12	16	20	28	36	52	72	83	99	124	143	171	206	245	
	Rated Voltage/Frequency	3-phase AC 200V~240V (-15% ~ +10%), 50/60Hz																
	Operating Voltage Range	170~265Vac																
	Frequency Tolerance	47~63Hz																
Cooling method	Natural Cooling		Fan Cooling															
Braking Chopper	Frame A,B,C: Built-in											Frame D and above: Optional						
DC choke	Frame A, B, C: Optional											Frame D and above: 3% built-in						
EMI Filter	Optional																	

Table 4. VFD CORE 480 VAC, Input and Output Rating

Frame		A						B			C			D				
Models HCRDCxxxx1000T		1hp	2hp	3hp	5hp	7.5hp	10hp	15hp	20hp	25hp	30hp	40hp	50hp	60hp	75hp	100hp	125hp	
Output Rating	Normal "HVAC" Duty - Variable Torque	Rated Output Capacity (kVA)	2.4	2.9	4	6	9.6	11.2	18	24	29	36	45	57	73	88	115	143
		Rated Output Current (A)	3	3.7	5	7.5	12	14	22.5	30	36	45	56	72	91	110	144	180
		Applicable Motor Output (kW)	0.75	1.5	2.2	3.7	5.5	7.5	11	15	18.5	22	30	37	45	55	75	90
		Applicable Motor Output (HP)	1	2	3	5	7.5	10	15	20	25	30	40	50	60	75	100	125
		Overload tolerance	120% of rated current for 1 minute															
		Max. output frequency (Hz)	600.00Hz (90KW~: 400.00Hz)															
		Carrier Frequency (kHz)	2~15kHz (8KHz)									2~10kHz (6kHz)					2~9 kHz (4KHz)	
	Heavy Duty - Constant Torque	Rated Output Capacity (kVA)	2.2	2.4	3.2	4.8	8.4	10	14	19	25	30	36	48	58	73	88	120
		Rated Output Current (A)	2.8	3	4	6	10.5	12	18	24	32	38	45	60	73	91	110	150
		Applicable Motor Output (kW)	0.4	0.75	1.5	2.2	4	5.5	7.5	11	15	18.5	22	30	37	45	55	75
		Applicable Motor Output (HP)	0.5	1	2	3	5	7.5	10	15	20	25	30	40	50	60	75	100
		Overload tolerance	120% of rated current for 1 minute;160% of rated current for 3 seconds															
		Max. output frequency (Hz)	600.00Hz(90KW~: 400.00Hz)															
		Carrier Frequency (kHz)	2~15kHz (8KHz)									2~10kHz (6kHz)					2~9 kHz (4KHz)	
Input Rating	Input Current (A) Normal Duty	4.3	5.4	7.4	11	18	20	25	33	39	47	58	76	91	110	144	180	
	Input Current (A) Heavy Duty	3.5	4.3	5.9	8.7	15.5	17	20	26	35	40	47	63	74	101	114	157	
	Rated Voltage/Frequency	3-phase AC 380V~480V (-15%~+10%), 50/60Hz																
	Operating Voltage Range	323~528Vac																
	Frequency Tolerance	47~63Hz																
Cooling method		Natural Cooling				Fan Cooling												
Braking Chopper		Frame A,B,C: Built-in												Frame D and above: Optional				
DC choke		Frame A, B,C: Optional												Frame D and above: 3% DC built-in				
EMI Filter		Frame A, B, C - EMI filter NOT built-in												Frame D and above: Optional				

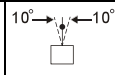
Table 5. Product Nomenclature

HCRD	A	0010	A	1	00T
					Options
					00T = Drive Only with Text Display
				Enclosure Type	
				1 = NEMA 1	
			Frame Size		
			A, B, C, D, E - See dimensional table		
		Nominal Horsepower			
		0007 = .75 Horse Power			
		0010 = 1 Horse Power			
		0100 = 10 Horse Power			
	Nominal Voltage				
	A= 208/230Vac Drive Alone, 208Vac Bypass				
	B = 230Vac Bypass				
	C = 480Vac				
	D = 575Vac				
Product Family					
HCRD = CORE Drive					

Table 6. VFD CORE Weight and Dimension in mm [inch].

208/230Vac	460Vac	HP	Weight (kg.)	Frame	W	H	D
HCRDA0010A1000T	HCRDC0010A1000T	1	2.8	A	130 [5.12]	250 [9.84]	170 [6.69]
HCRDA0020A1000T	HCRDC0020A1000T	2	2.8				
HCRDA0030A1000T	HCRDC0030A1000T	3	2.8				
HCRDA0050A1000T	HCRDC0050A1000T	5	2.8				
HCRDA0075A1000T	HCRDC0075A1000T	7.5	2.8				
	HCRDC0100A1000T	10	2.8				
HCRDA0100B1000T		10	4.6	B	190 [7.48]	320 [12.60]	190 [7.48]
HCRDA0150B1000T	HCRDC0150B1000T	15	4.6				
HCRDA0200B1000T	HCRDC0200B1000T	20	5.6				
	HCRDC0250B1000T	25					
HCRDA0250C1000T		25	10.5	C	250 [9.84]	400 [15.75]	210 [8.27]
HCRDA0300C1000T	HCRDC0300C1000T	30	10.5/8.7				
HCRDA0400C1000T	HCRDC0400C1000T	40	10.5/8.7				
	HCRDC0500C1000T	50	9.4				

Table 6. VFD CORE Weight and Dimension in mm [inch].

208/230Vac	460Vac	HP	Weight (kg.)	Frame	W	H	D
HCRDA0500D1000T		50	35.5	D	330 [12.99]	688.3 [27.10]	275 [10.83]
HCRDA0600D1000T	HCRDC0600D1000T	60	35.5				
	HCRDC0750D1000T	75	35.5				
	HCRDC1000D1000T	100	40.5				
	HCRDC1250D1000T	125	40.5				
HCRDA0750E1000T		75	45.7	E	370 [14.57]	715.8 [28.18]	300 [11.81]
HCRDA1000E1000T		100	46.2				
HCRDA1250E1000T		125	54.7				

WIRING DIAGRAMS

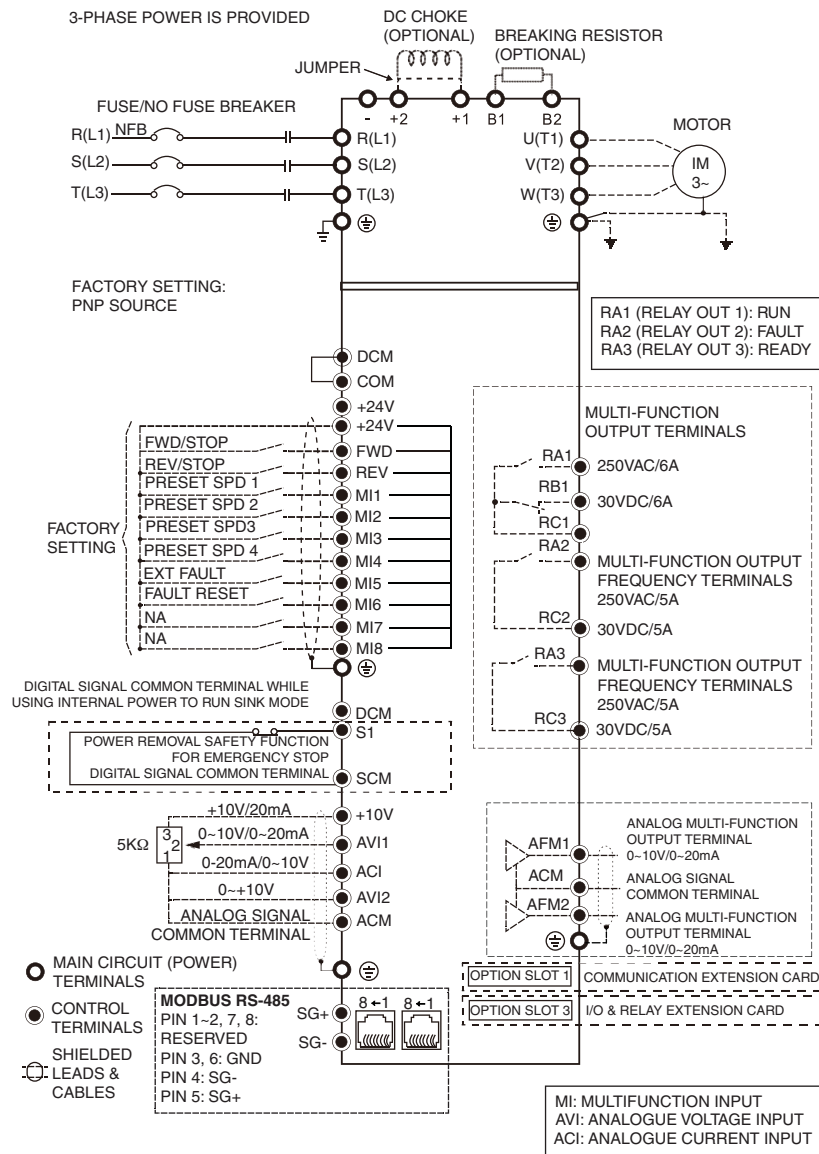

Fig. 1. Wiring Diagram for Frame Size A, Size B, and Size C

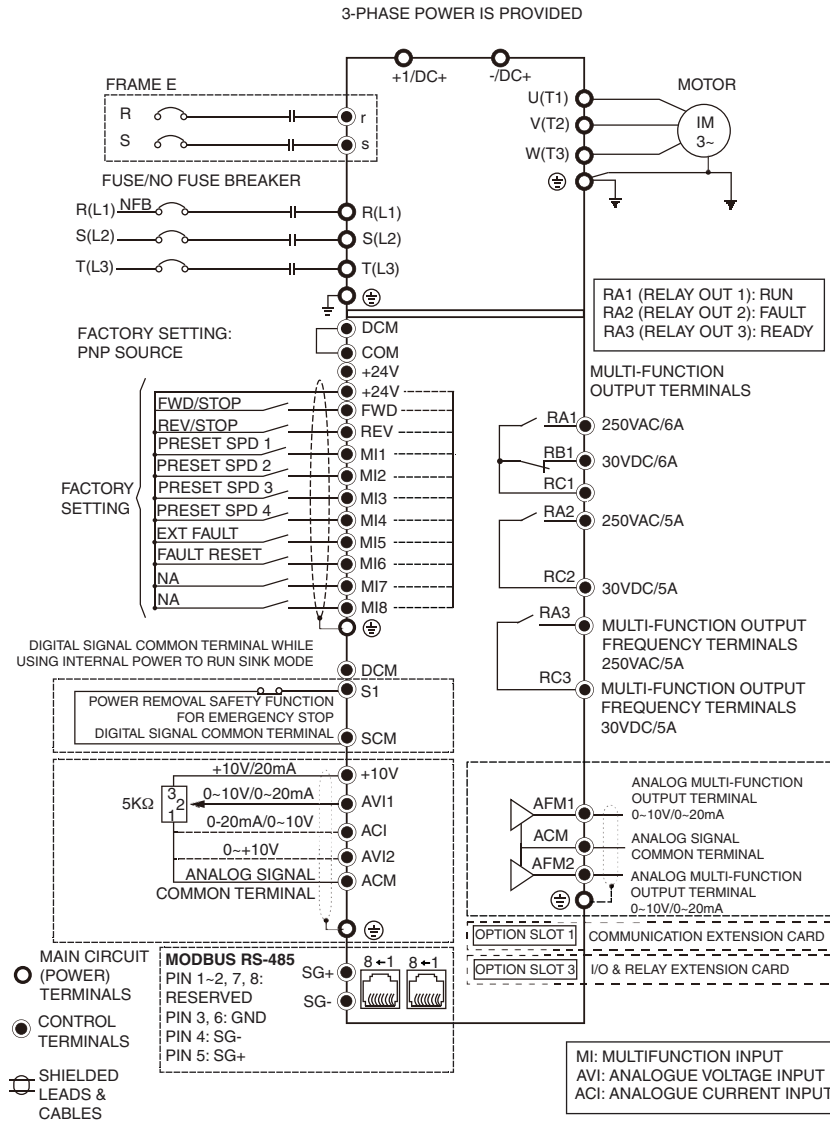

Fig. 2. Wiring Diagram for Frame Size D and Size E

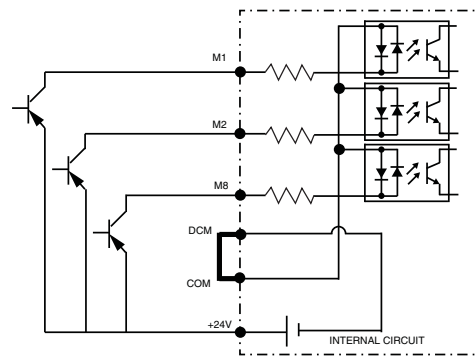

Fig. 3. Source Mode with internal power (+24 VDC)

Automation and Control Solutions

Honeywell International Inc.
 1985 Douglas Drive North
 Golden Valley, MN 55422
 customer.honeywell.com

© U.S. Registered Trademark
 © 2012 Honeywell International Inc.
 63-4380-01 M.S. 02-12
 Printed in United States

